



10W JUNCTION BOX EYE WASH STATION SERIES

DESCRIPTION

The all in one 10W junction box luminaire is small but powerful. This LED fixture also features pulse width modulation, electronic thermal management and a Failsafe redundant circuit design that allows the light to function even if half the light should fail in extreme conditions.

The 180° ultra-wide flood beam pattern and intense green color leads temporarily visually impaired workers quickly to an eye wash station aiming to prevent permanent eye damage.

MECHANICAL:

Fixture Weight:	2 lbs (0.9kg)
Shipping Weight:	4 lbs (1.8kg)
Mounting:	(4) 3/4" NPT - SIDES

TECHNICAL:

LED:	5630 (LG) X 40EA
Lumens:	1,000 lm
Beam Pattern:	180°
Wattage:	10W
Amp Draw:	0.09A@115V AC 0.04A @ 230V AC 0.04 @ 277V AC
Color Temperature:	-
Operating Voltage:	90-264V AC 127-370V DC
Operating Temp:	-40°C ~ 60°C
Lifespan:	50,000 hrs
Frequency:	47-63Hz
THD:	<20% (@load≥50% 115VAC,230VAC) (@load≥75% / 277VAC)
Power Factor:	≥ 0.98/115VAC ≥ 0.95/230VAC ≥ 0.92/277VAC
Short Circuit:	Constant Current Limiting, Recovers Automatically After Fault Condition is Removed
Polarity:	Reverse Polarity Protection
Battery Back-Up:	N/A

CONSTRUCTION:

Housing Material:	Die-Cast 6061 Aluminum
Finish:	Gloss Grey
Lens:	Polycarbonate



PART #:	BEAM PATTERN	COLOR
LSGSM40180PCVG	180° Ultra-Wide Flood	Green

2D DRAWING:

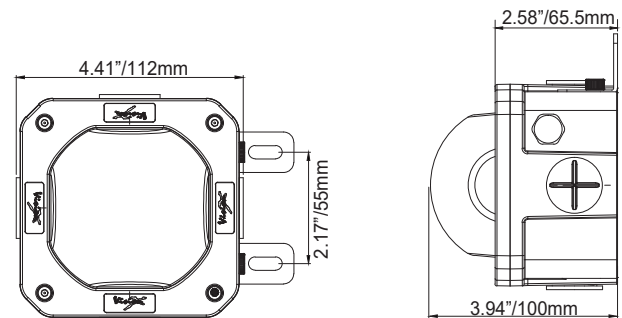

RATINGS:

EMC Emission:	Compliance to EN55022,EN61000-3-2 Class A ,EN61000-3-3
EMC Immunity:	Compliance to EN55024, EN61000-4-2,3,4,5,6,8,11; light industry level(surge 2KV), criteria A
UL1598A Marine:	✓
Ingress Protection:	IP-68, IP69k
Vibration Rating:	15.6 Grms
Warranty:	5 Years